

Quick start guide

Step 1: Pop up the trap body by unlatching the strap from the hook.

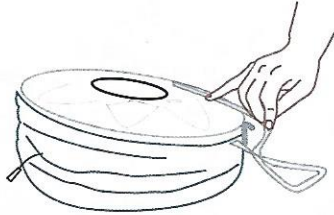

Step 2: First attach the funnel net (optional) and then the catch bag over the protruding ring of the intake funnel.

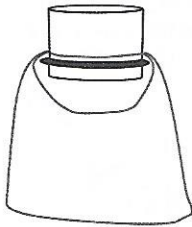

Step 3: Insert the intake funnel with the attached funnel net and catch bag into the opening on top of the cover.



Step 4: Remove the label from the BG-Lure cartridge.

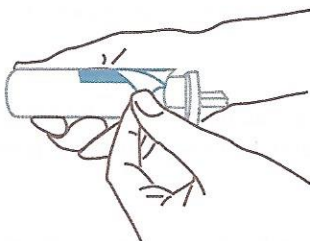

Step 5: Pop out the white Biogenics disc from the hole in the cover and place the BG-Lure cartridge into the hole.

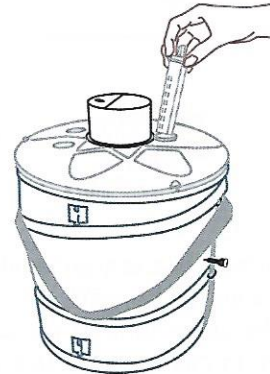

Step 6: Connect the battery to the battery cable or plug in the power transformer.

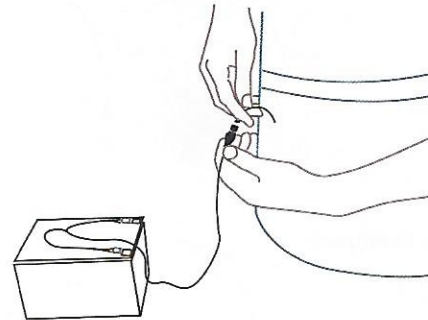

When the power is turned on the shutter will automatically tilt open.

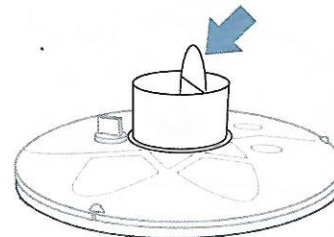

Please note:

The smell of the new material of the traps might have repellent effects on the mosquitoes. Therefore, we recommend to air out the traps by running them outside for two weeks before using them in the field to get rid of the smell.

Positioning of the trap

The correct placement of the trap is an important factor that heavily influences its effectiveness.

Position the trap in a location that is sheltered from

- direct sunlight
- wind
- heavy rainfall



No sun

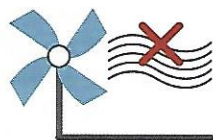

No wind



No heavy rain

Position the trap in a location that is close to

- shadowy resting areas of mosquitoes such as bushes, shrubs, hedges, or any other foliage.
- mosquito breeding sites



Shadow



Resting areas



Humidity and breeding areas

A location under a bush is a very good position since mosquitoes rest under the leaves. However, please pay attention that the trap and all its upper surfaces are clearly visible to patrolling mosquitoes, so that its specialized appearance is effective in attracting the mosquitoes. Therefore, do not place the

traps under very dense bushes. A distance of at least 0.5 meters above the top of the trap needs to be kept clear. Any distance lower will hinder the visual signals and air currents of the trap, and consequently reduce the catch rate.



Positioning examples:

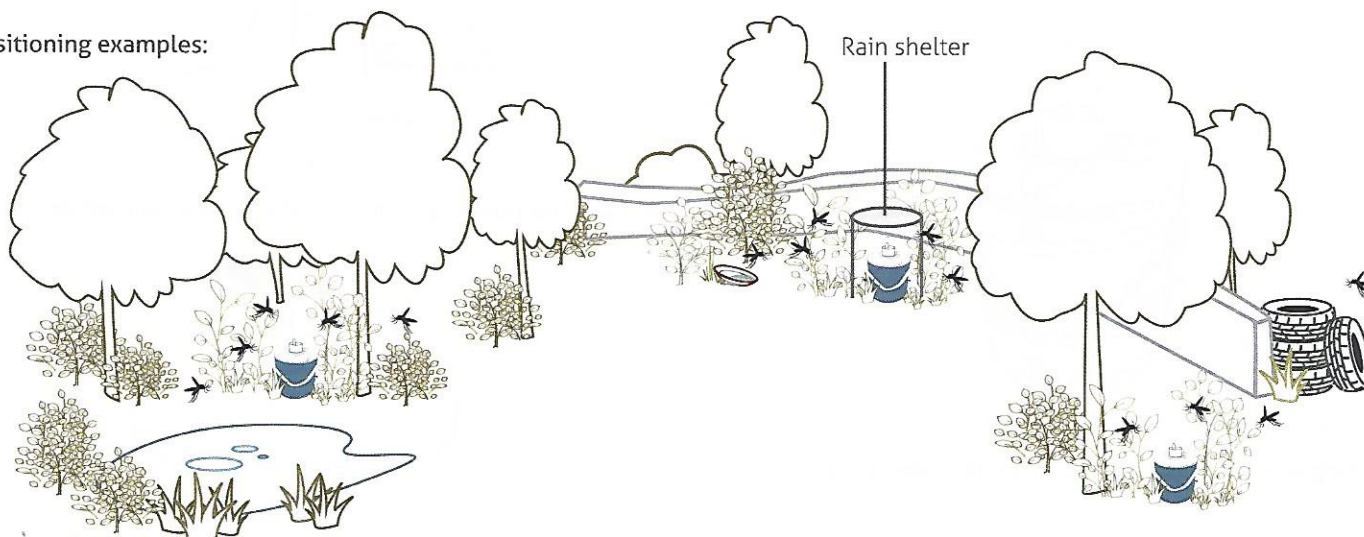

Sheltering the trap from heavy rainfall:

Please note:

Heavy rainfall might disrupt the airflow by clogging the pores of the cover. This causes a reduction in the suction power of the ventilator. Therefore ensure that the trap is sheltered from heavy rainfall. If the trap becomes very wet allow it to dry before the next monitoring.

Even though heavy rainfall does not damage the trap, there are several negative effects of heavy rainfall that might decrease the catch rate:

- The mosquitoes can be damaged and difficult to identify.
- Mosquitoes avoid rain and prefer sheltered positions. In sheltered positions the catch rate can be therefore higher.
- Rain clogs the pores of the cover which leads to a reduction

Product components

1. Intake funnel
2. Funnel net
3. Catch bag (2x)
4. Trap cover
5. Inner cylinder with attached ventilator
6. Trap body
7. Battery cable
8. Power cord with transformer (optional)
9. BG-Lure cartridge (optional)
10. CO₂ emitter nozzle with attached CO₂ tube (optional)
11. Pressure reducing regulator for CO₂ (optional)

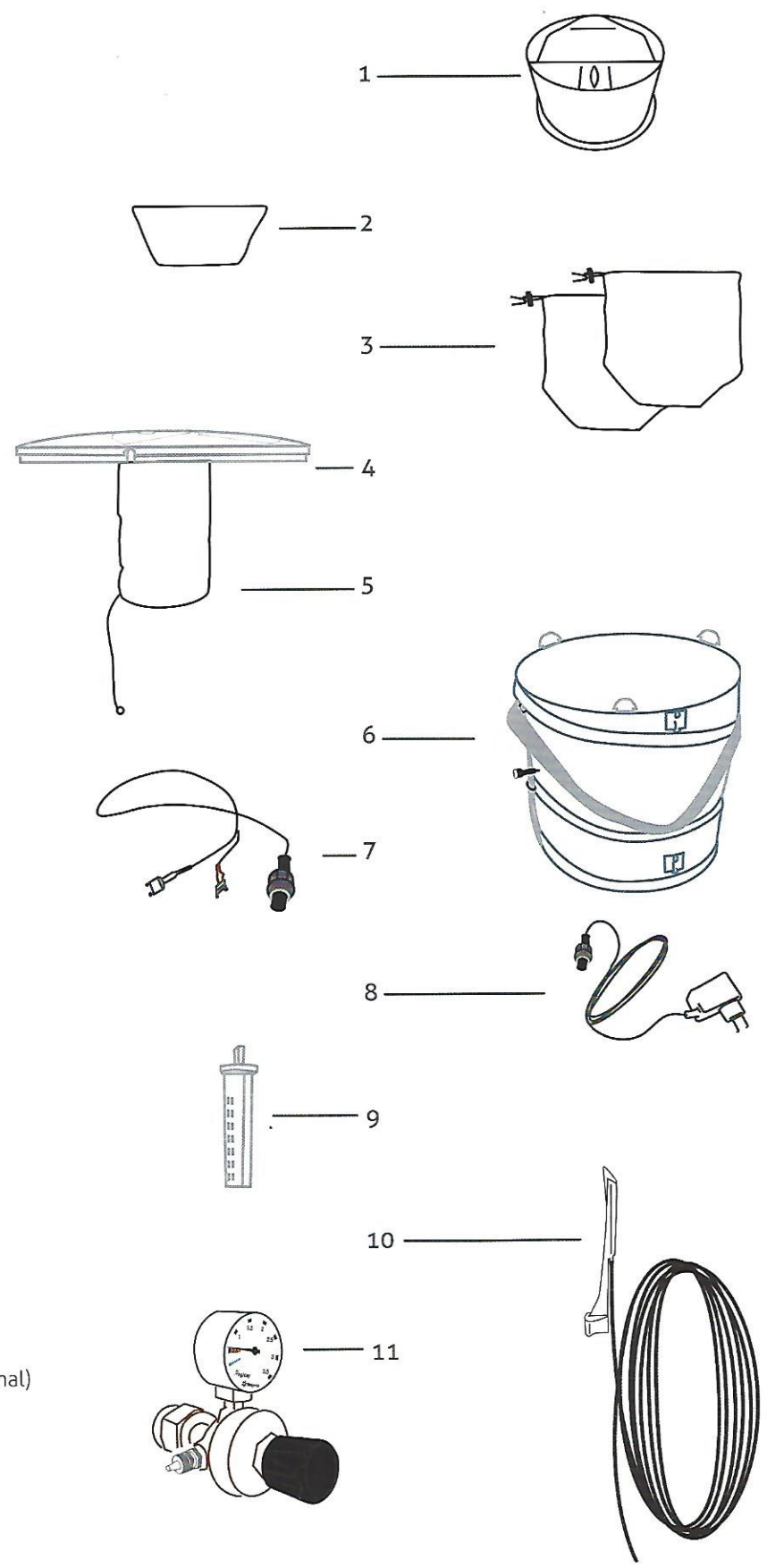

Assembling the trap

Please note:

The smell of the new material of the traps might have repellent effects on the mosquitoes. Therefore, we recommend to air out the traps by running them outside for two weeks before using them in the field to get rid of the smell.

1. Open the Biogents trap carrying bag, and take out the components [F1].
2. Unhook the eyelet on the carrying handle, and pop up the trap body [F2].
3. First attach the funnel net (optional) and then the catch bag over the protruding ring of the intake funnel [F3]. Tighten the top part of the catch bag.
4. Insert the intake funnel with the attached funnel net and catch bag into the opening on top of the cover [F4].
5. Unwrap the plastic label from the BG-Lure cartridge [F5].
6. Pop out the white Biogents disc from the hole in the cover when using the BG-Lure cartridge [F6].

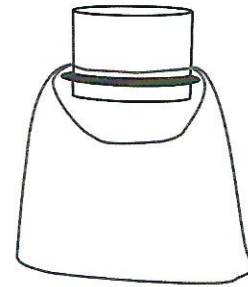

F3

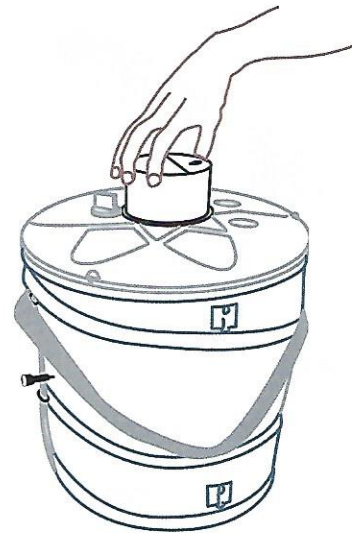

F4

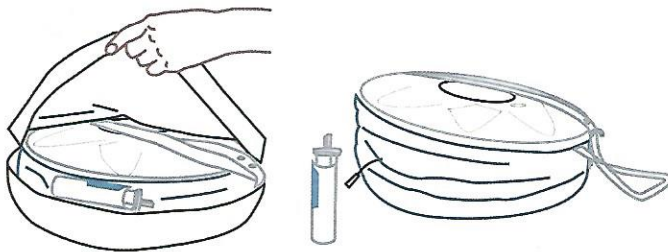

F1

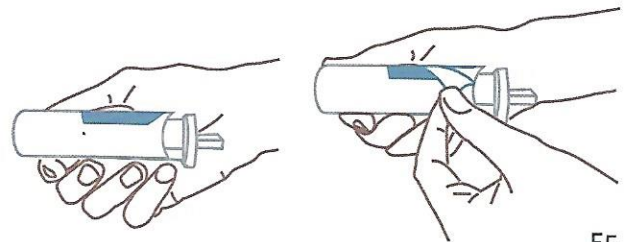

F5

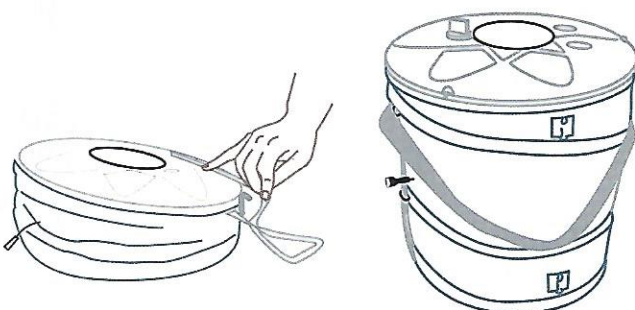

F2

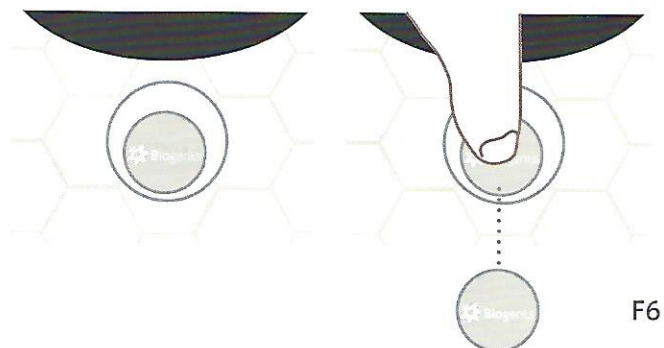

F6

6. Insert the desired attractant into the trap. When using the BG-Lure cartridge, it can be placed into the hole in the cover [F7].

7. Connect the battery to the battery cable [F8]. Alternatively you can plug in the power transformer [F10]. Connect the open ends of the battery cable with the ventilator cable. Please pay attention to always connect with the arrows in one line [F9].



F7

8. When the power is turned on, the shutter will automatically tilt open [F11]. When the power is shut off, or if the battery fails, the shutter automatically closes which ensures that the caught mosquitoes cannot escape.

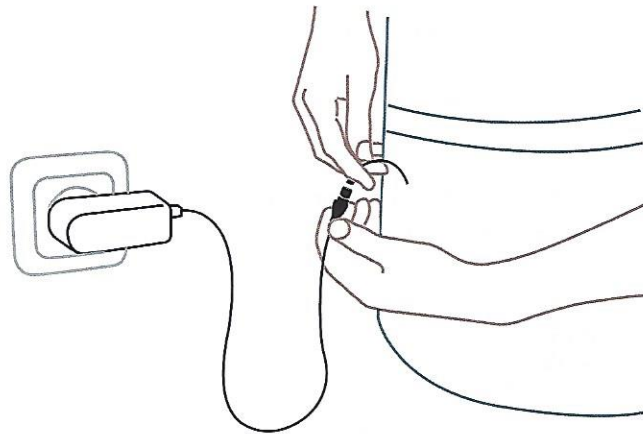

F10

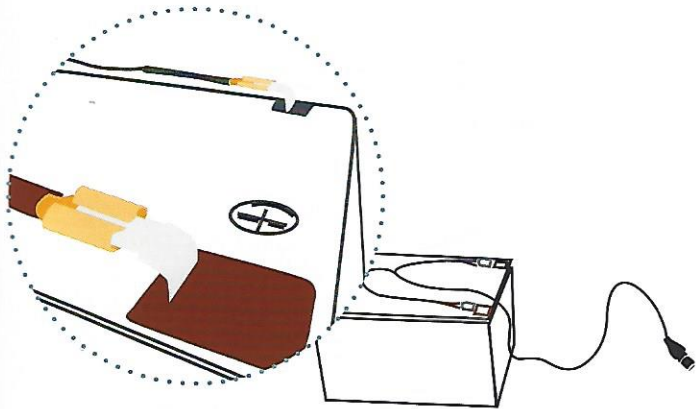

F8

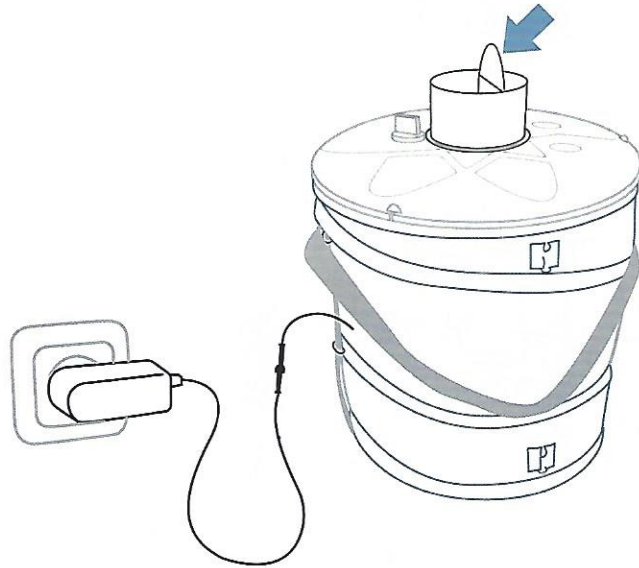

F11

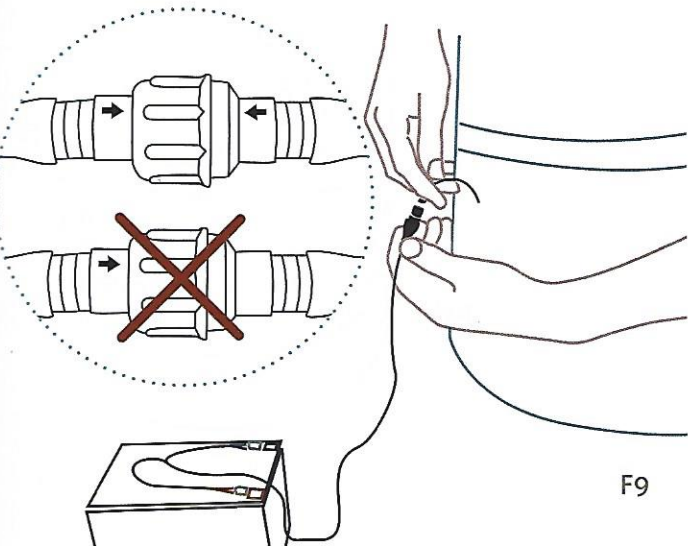

F9

9. Alternatively, you can place the battery within the body of the trap. For this purpose open the trap by unhooking the clips of the cover [F12], and remove the cover [F13].
10. Place the battery into the fixed straps located on the bottom of the body, and tighten the strap [F14].
11. Connect the battery cable to the battery [F15], and guide the other end of the cable out of the opening on the side of the trap [F16].
12. Connect the open ends of the battery cable with the ventilator cable [F17]. The trap is now running, and the shutter of the intake funnel will tilt open. You can easily disconnect and connect the cables to switch the trap off or on without the need of opening the trap body.

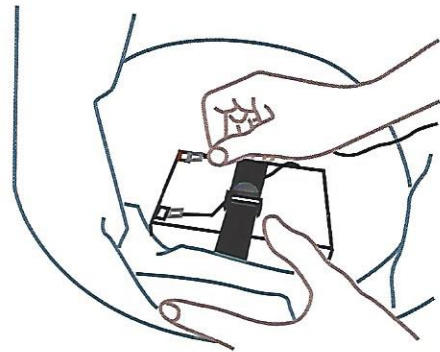

F15

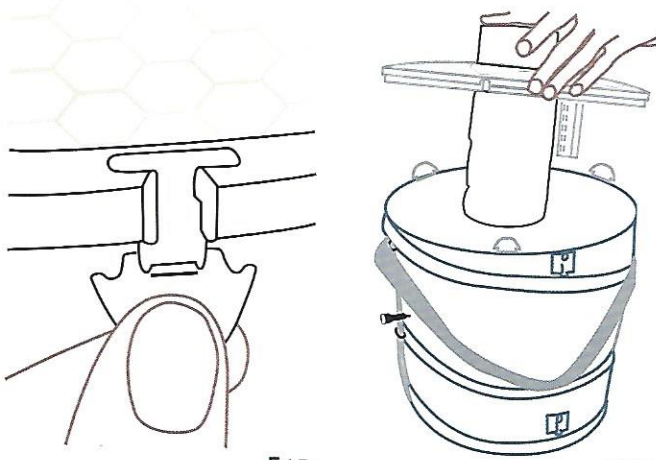

F12

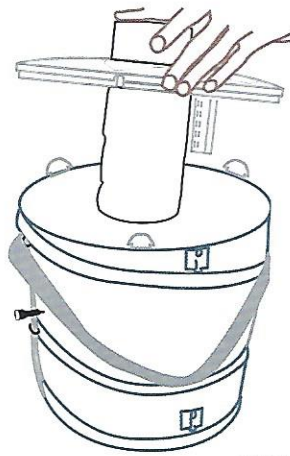

F13

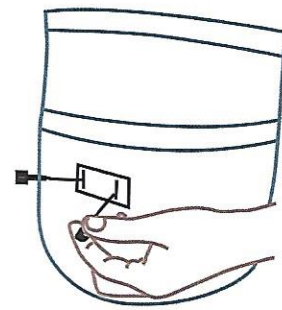

F16

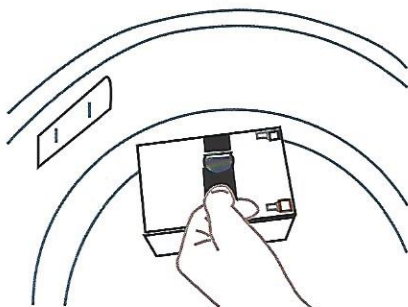

F14

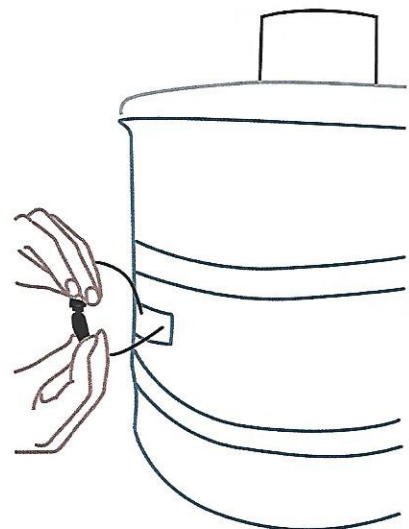

F17

Maintenance and care

To clean the plastic parts of the trap and the catch bags, use clear water. Do not use any cleaning agents or solvents, because the residues from these products can have a repelling effect for the mosquitoes, and consequently reduce the catch rate of the trap.

Replacing the catch bag

The intake funnel together with the catch bag can be used as a collection and transportation unit. The new shutter in the intake funnel can be fixed for this purpose, and will ensure that no mosquitoes escape during transport.

1. To remove the mosquitoes, first fix the shutter of the intake funnel by pressing together the intake funnel at the axis of the shutter, and then pressing the tab down [F18]. The tab is now secured, and the shutter cannot open.
2. Then remove the intake funnel with the catch bag by turning it counterclockwise and pulling it out [F19].
3. Alternatively, you can also remove the catch bag from the intake funnel. Lift the intake funnel approximately 10 cm out of the trap keeping the catch bag within the suction current of the ventilator to ensure no mosquitoes escape. Carefully pull the catch bag off the intake funnel, and simultaneously pull the cord of the catch bag tightly shut. You can set the intake funnel on the side of the trap while closing the catch bag [F20].

For further use of the insects (e.g., identification/classification), it is best to put them in a freezer for at least an hour to kill them. **Please be careful when handling the funnel when taking it out of the freezer. The plastic of the cold funnel may break easily when falling to the ground.** After several hours (or in some cases up to a day depending on ambient temperature and humidity), the caught mosquitoes will dehydrate and die within the trap. The trap does not damage the insects, but identification is complicated if the insects stay in the trap for more than three days and dry out, or if they get wet. You should attach the catch bag to the intake funnel with the seam facing outwards in order to avoid mosquitoes getting stuck in the seam while emptying the catch bag.

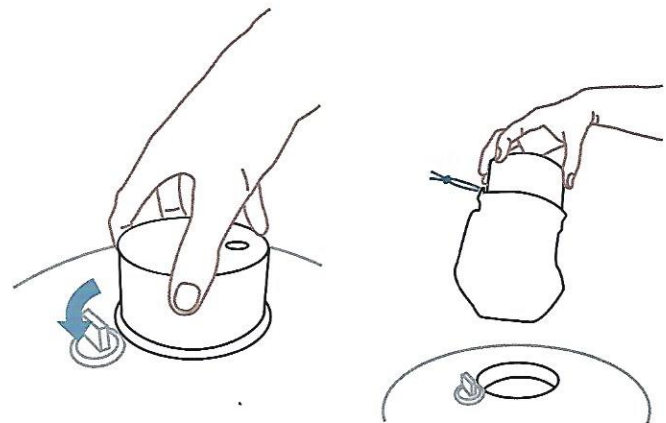
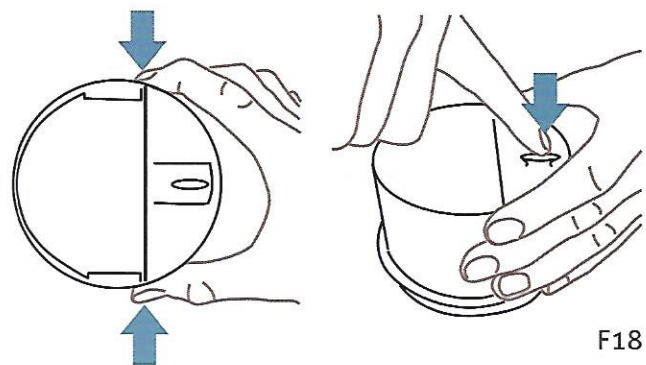

Administering the carbon dioxide

Without CO₂ the BG-Sentinel catches *Aedes aegypti*, *Aedes albopictus*, and *Aedes polynesiensis*, which are vectors of dengue, chikungunya, filariasis, and yellow fever. It also catches some *Culex* species such as *Culex quinquefasciatus* and *Culex pipiens*; however, the addition of CO₂ enables you to catch a broader range of blood seeking species as well as much higher numbers of the previous mentioned species. Various sources of CO₂ can be used. The optional CO₂ nozzle can be attached to a gas cylinder, to any well insulated dry ice container, or to another CO₂ source that fits your preference, and that is placed away from the trap.

Fermentation of yeast:

Yeast-produced carbon dioxide can be produced by mixing 17.5 g of dry yeast, 250 g of sugar, and 2½ L of tap water, or 35 g of dry yeast, 500 g of sugar, and 2½ L of tap water in a 5 L-bottle. Capturing the foam to prevent the foam from entering the traps can be accomplished by a set up with two bottles. See detailed information for this protocol in a publication at <http://www.ncbi.nlm.nih.gov/pubmed/20973963>.

CO₂ gas cylinders:

In order to supply the trap with the carbon dioxide (CO₂) attractant, a commercially available CO₂ gas cylinder with two or more kilograms can also be used. These can be acquired or rented at drink retailers or bottle depots for a deposit. A door-to-door delivery service may also be possible. We recommend a 10-kg gas cylinder, which is also used in restaurants for draft beer and soda.

Attaching the pressure reducing regulator onto the CO₂ gas cylinder:

The BG-Sentinel CO₂ trap includes a specialized pressure reducing regulator for an optimal adaption of the CO₂ emission to the local and seasonal conditions. Screw the pressure reducing regulator onto the CO₂ gas cylinder by rotating the screw on the end of the regulator onto the opening on the CO₂ cylinder, and make sure it is tight by using a wrench or pliers [F21].

Attaching the CO₂ tube:

The BG-Sentinel CO₂ set includes a CO₂ tube. One end of the CO₂ tube is attached to the CO₂ emitter nozzle, and the other end is to be attached to the pressure reducing regulator: Unscrew the nut on the outlet of the pressure reducing regulator [F22, (1)]. Thread the end of the CO₂ tube through the nut [F23]. Then fix the end of the CO₂ tube onto the outlet [F24], and re-screw the nut back onto the outlet with a wrench size 12.

Attaching the CO₂ emitter nozzle on the trap:

Fix the CO₂ emitter nozzle with the attached CO₂ tube onto the BG-Lure cartridge [F26]. If the BG-Lure is not used, insert the CO₂ nozzle into the same opening on the cover.

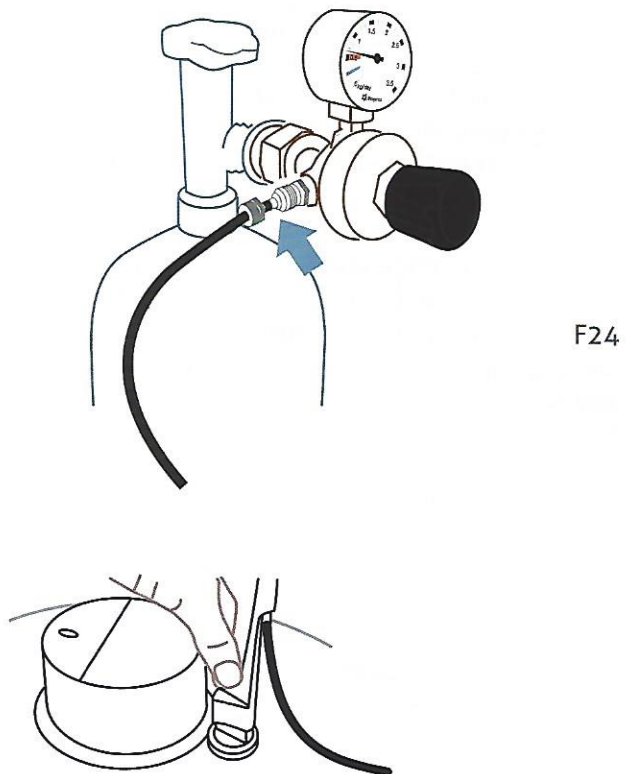
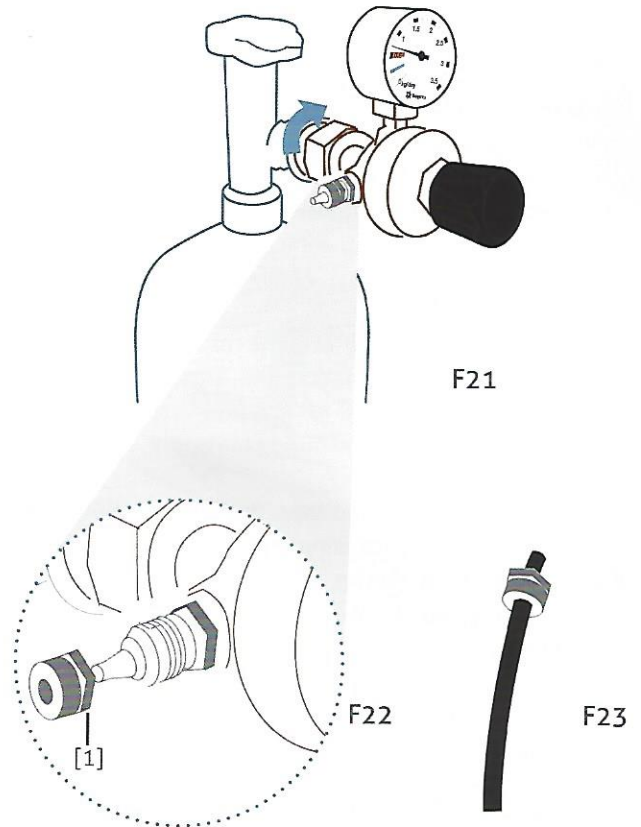

Adjusting the CO₂ consumption:

Open the valve on the CO₂ gas cylinder [F27, (1)] by turning it counterclockwise until it is completely open.

The pressure can be adjusted to the local and seasonal conditions with the black knob on the front of the pressure regulator [F27, (2)]. To increase flow rate, turn to the right. To decrease flow rate, turn to the left. We recommend a flow rate of 0.5 kilogram/day (red marker on the display of the pressure regulator). With higher flow rates up to 1.5 kilogram/day it is possible to further increase catch rates.

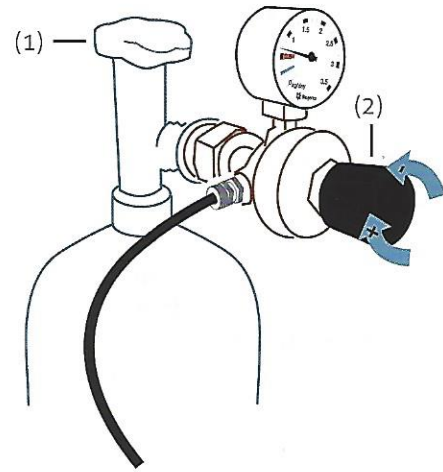

F27

The following is a consumption table of CO₂ comparing two CO₂ flow rates:

Consumption Table of Carbon Dioxide	CO ₂ Flow Rate in kg/day	CO ₂ Flow Rate in ml/min	Number of days a 10kg CO ₂ cylinder lasts
	0.5	200	20
	1.5	600	6.5 days

Positioning of the trap

The correct placement of the trap is an important factor that heavily influences its effectiveness. A detailed description of how to best position the traps can be found in the internet at:

<http://www.biogents.com/wp-content/uploads/Placement-and-effect-of-Biogents-mosquito-traps-en.pdf>

For catching *Aedes aegypti*, please also see "indoor use".

General

Outdoor use (the trap can be operated with or without CO₂):

The trap should be placed outside from spring to autumn: average temperature > 15° C.

Position the trap in a location that is sheltered from direct sunlight, wind, and heavy rainfall [F28].

For best results, position the trap in a shady, humid location close to mosquito breeding spots or resting zones [F29], e.g., in shrubs or under trees, near puddles or rain barrels. Rainfall will not damage the trap as long as the fan is switched on.

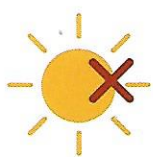

No sun

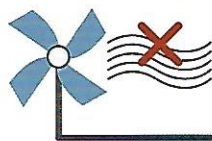

No wind



No heavy rain



Shade



Resting areas



Humidity and breeding areas

F28

F29

In detail:

- Ideal locations to position the trap are close to resting areas of mosquitoes such as bushes, shrubs, hedges, or any other foliage.
- The trap should also be positioned close to mosquito breeding sites such as various kinds of temporary stagnant water ranging from small lakes to collections of rain water in rain barrels or old tyres. Many mosquitoes do not need a large amount of water for breeding; even a can filled with rain water can be an ideal breeding place.
- **Important:** A location under a bush is a very good position since mosquitoes rest under the leaves. But please pay attention that the trap and all its upper surfaces are clearly visible to patrolling mosquitoes, so that its specialized appearance is effective in attracting the mosquitoes. Therefore, do not place the traps under very dense bushes [F30]. A distance of at least 0.5 meters above the top of the trap needs to be kept clear [F31]. Any distance lower will hinder the visual signals and air currents of the trap, and consequently reduce the catch rate.



F30



F31

- Keep the trap out of direct sunlight since mosquitoes avoid the sun.
- Keep the trap out of wind. Winds not only deter the mosquitoes, but can also affect the suction from the ventilator decreasing the catch rate.
- Sheltering the trap from heavy rain:
A sheltered position (e.g., in a sparse shrub [F31], under a tree, or under a roof) has a positive effect on the catch rate. Here even rainfall does not affect the catch rates.
However, if the trap is exposed to heavy rainfall, there are negative effects that might decrease the catch rate even though heavy rainfall does not damage the trap:
 - The mosquitoes can be damaged and difficult to identify.
 - Mosquitoes avoid rain and prefer sheltered positions. In sheltered positions the catch rate can be therefore higher.
 - Rain clogs the pores of the cover which leads to a reduction of suction power causing the shutter to close.
 - Other animals such as snails are attracted by a wet trap, and tend to creep into the trap.

If you do not find a naturally sheltered position for the trap, it would be best to position the trap under a roofed area or a self-made shelter to keep it out of direct rainfall.

It is important to comply with the following regulations when sheltering the trap from rain:

- Whatever is placed over the trap must be at least 0.5 meters above the top surface of the trap. Any distance lower will hinder the visual signals and air currents of the trap, and consequently reduce the catch rate.
- Make sure the shelter covers an adequate area around the trap so that rain cannot enter from the sides.
- Make sure the shelter is stable and durable.

Indoor use (do not add CO₂) for catching *Aedes aegypti*:

Aedes aegypti breeds in close proximity to humans in areas of stagnant water, such as flower vases, uncovered barrels, buckets, and discarded tires. However, they also breed indoors, e.g., in wet shower floors or toilet tanks.

Therefore, it can be necessary to position the traps indoors to catch *Aedes aegypti*. It is important that the trap is not placed in front of or close to backgrounds with a lot of contrast (i.e., in front of a book shelf), because the trap uses a black and white contrast as a visual stimulus. In this case, the mosquitoes could be distracted from the trap. A good position would be in front of the window, for example. The trap is a competitor with human beings. To optimize results, leave the trap constantly running even if no humans are present in the room/house for a period of time, and leave interior doors open to allow mosquitoes to find the trap.

Positioning examples:



Power supply and electricity

The ventilator requires a power source of 9 to 12 V DC (max. 280 mA). While a battery cable is included, an optional power supply unit (EU version, US version or Australian version with an input of 220 V and an output of 12 V) with fitting plug connection is also available.

When using batteries, we usually recommend 12 Volt motorcycle or car batteries. These are easily rechargeable and readily available in most places. As a rule of thumb, you will need a battery capacity of 10 to 11 Ah for each trap with a 24 h trapping period (for a 48 h period you will need a capacity of 20 to 22 Ah and so on). This includes a security factor which should give you a peace of mind in most real-life situations.

Technical data

Weight: 1.7 kg

Dimension unfolded: 38 x 47 cm

Dimension folded in bag: 42 x 13 cm

Ventilator: 12 V DC, 3.6 W

Switching power supply: AC Input 100 – 230 V,
Frequency 60 Hz/50 Hz,
DC Output 12 V 1 A